

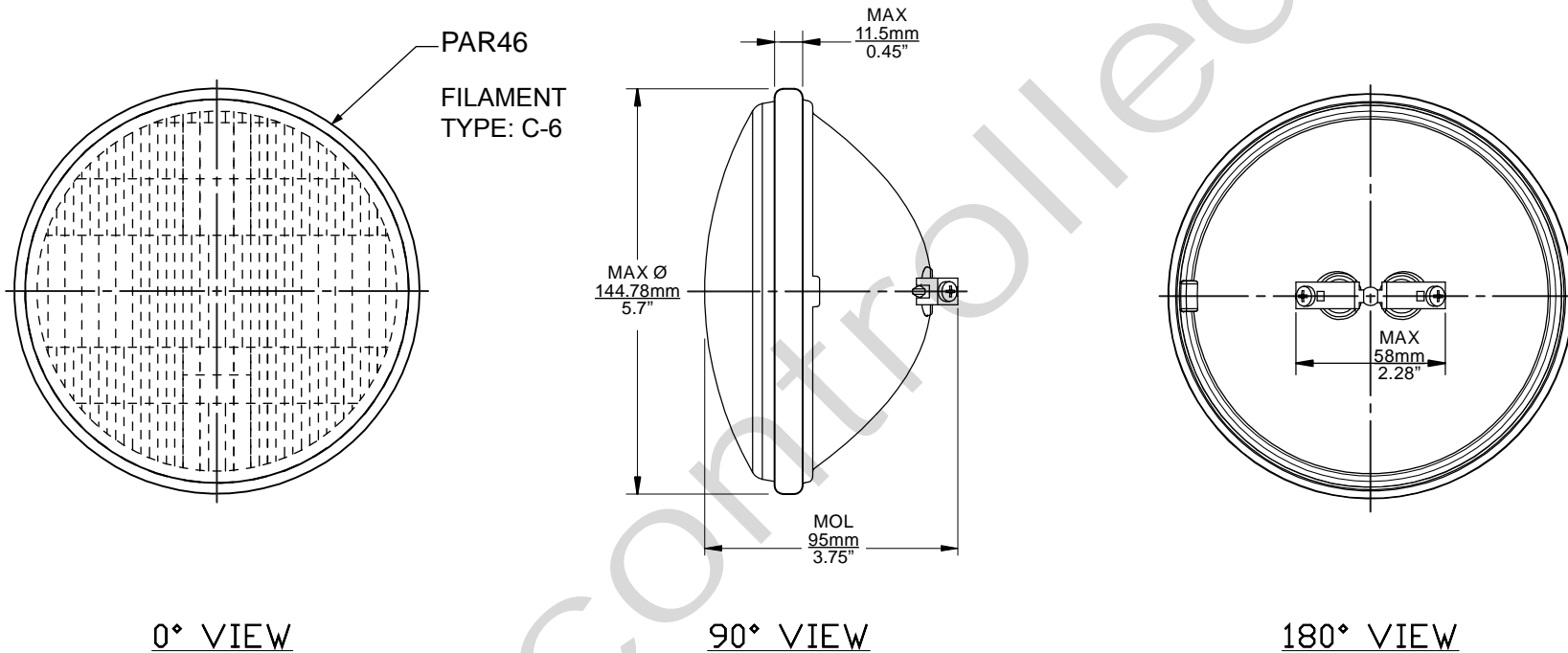

Since 1959

PART NO.	BASE TYPE	DESIGN VOLTS	DESIGN WATTS	APPROX. INITIAL MAX CP	BEAM SPREAD HOR. X VER. DEGREES	AVERAGE LIFE HOURS (AT 14V)	REVISIONS			
							REV #	DESCRIPTION	DATE	APPROVED
4412	2 SCREW TERMINALS	12.8	35	11,000	40 X 5	100	1	ISSUED	10/05/2016	RM

4412 12.8V 35W



UNLESS OTHERWISE SPECIFIED: DIMENSIONS ARE IN INCHES TOLERANCES		CEC INDUSTRIES LTD	
DECIMALS	ANGULAR	599 BOND STREET	LINCOLNSHIRE, IL 60069
.XX ± .05	± 0.5°		
.XXX ± .010			
FRACTIONAL	± 1/64		
DRAWN	DATE	TITLE	
ROSE MEDINA	10/05/2016	SEAL BEAM 4412	
CHECKED	SIZE	FSCM NO.	DWG NO.
	A		4412
DESIGN	SCALE	PLOT SCALE	SHEET 1 OF 1
MATERIAL	FILE	DRAWING NOT TO SCALE	
	4412.pdf		